



# Various Methods Involved in Studying Persistence and Residues of Pesticides in Soil

**D. Balaji Naik <sup>a\*</sup> and K. T. Gurumurthy <sup>b</sup>**

<sup>a</sup> Department of Soil Science and Agricultural Chemistry, College of Agriculture, Shivamogga, Karnataka, India.

<sup>b</sup> Keladi Shivappa Nayaka University of Agricultural and Horticultural Sciences, Shivamogga-577204, Karnataka, India.

## **Authors' contributions**

*This work was carried out in collaboration between both authors. Both authors read and approved the final manuscript.*

## **Article Information**

DOI: 10.9734/IJPSS/2022/v34i232506

## **Open Peer Review History:**

This journal follows the Advanced Open Peer Review policy. Identity of the Reviewers, Editor(s) and additional Reviewers, peer review comments, different versions of the manuscript, comments of the editors, etc are available here: <https://www.sdiarticle5.com/review-history/92905>

**Review Article**

**Received 17 August 2022**  
**Accepted 20 October 2022**  
**Published 31 October 2022**

## **ABSTRACT**

Pesticides protect plants or plant products from crop pests, plagues, and weed competition, improving yields and protecting the assembly's availability, quality, dependability, and economic competitiveness for the benefit of farmers and consumers. The introduction of cutting-edge technologies, from breeding to harvesting, has contributed to an increase in agricultural yields. These activities are aided by the use of agrochemicals, which in general endanger the environment's sustainability by polluting soils, water, and air. Pesticides' harmful effects pose a threat not only to nearby natural habitats, but also to cropland itself.

*Keywords: Pesticides; soil pollution; solvent extraction and health.*

## **1. INTRODUCTION**

Pesticides are a necessary component of modern agriculture. Pesticide production in India began in 1952 with the establishment of a plant

near Calcutta for the protection of BHC [1]. India is now Asia's second largest pesticide producer, trailing only China, and ranks 12th worldwide. India's production of technical grade pesticides has steadily increased from 5,000 metric tonnes

\*Corresponding author: E-mail: [balajinaikb998@gmail.com](mailto:balajinaikb998@gmail.com);

in 1958 to 102,240 metric tonnes in 2016 [2], [3]. India has the lowest pesticide consumption per capita, at 0.5 kg ha<sup>-1</sup>, when compared to other countries. Low purchasing power and small land holdings are the primary reasons for India's low pesticide per capita consumption. It appears that 800 pesticide molecules have been identified and 291 have been registered. Pesticides' general impact on the soil ecosystem, however, is caused by specific component combinations that exist there. The highest number of residues that the phenomenon has produced must be recognized in order to gain a better comprehension of the entire event [4].

Chromatography is a method of separating mixed components in a flow system using an adsorbent column. Samples are placed in the mobile phase as it flows through the stationary phases during chromatographic separation. HPLC was used to analyse thermolabile or highly polar compounds, as well as compounds with a high molecular weight. The accuracy of the chromatographers in selecting and using the column, stationary phase, and mobile phase also has a significant impact on the

success of an analysis. The advantages of HPLC separation over conventional methods include faster analysis times, lower costs, and the ability to analyse compounds with low stability.

### 1.1 Pesticides

Any chemical, biological substance, or mixture of substances used to prevent, destroy, attract, repel, or control pests. Pesticides can be used to kill insects (insecticides), rats and mice (rodenticides), weeds (herbicides), and fungi (fungicides) (fungicides). Pesticides are synthetic active substances that are widely used in agricultural land, particularly in grape-growing areas. Pesticides are commonly sprayed on vegetables and fruits to promote rapid and healthy growth. Pesticide droplets may contaminate the soil during the spray. The soil was also contaminated by pesticide leaching from plants or plant decay.

India use pesticides consumption in percentage as Insecticide 65 percent Herbicide 16 percent Fungicide 15 per cent others 4 per cent.

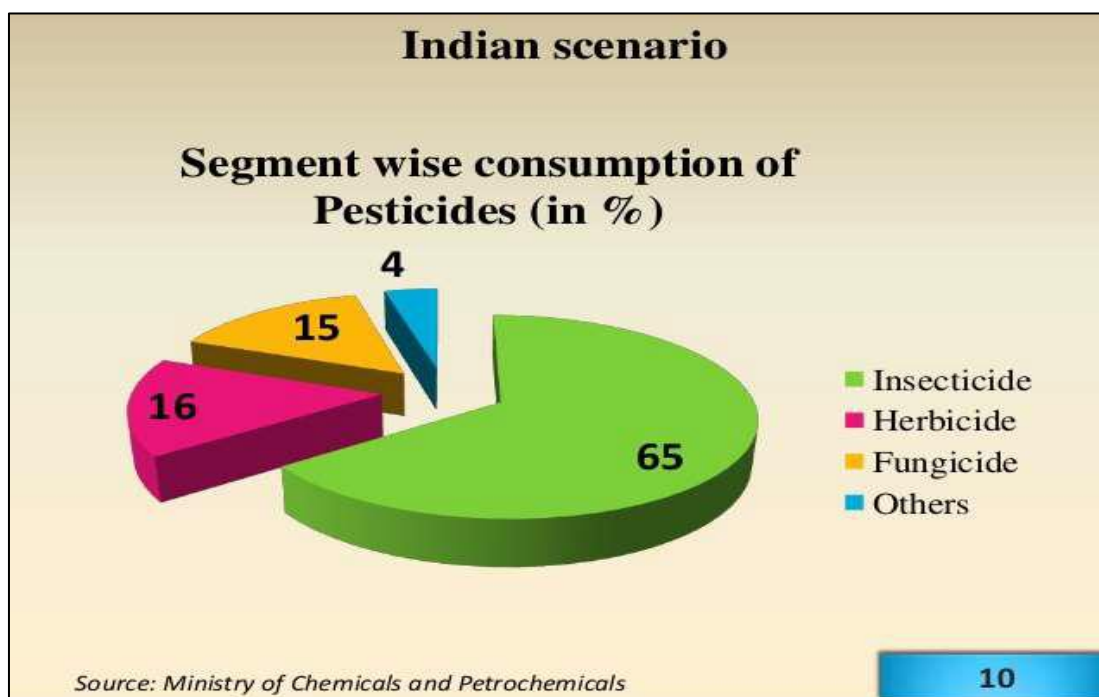

Image 1. Indian Scenario (ministry of chemical and petrochemical)

## 2. PESTICIDE RESIDUES

Pesticide residue means any substances in food, agricultural commodities or animal feed resulting from the use of pesticide. The term includes any derivatives of the pesticide such as specified derivatives, degradation & conversion products, metabolites, impurities and reaction products etc. which are considered to be of toxicological significance

- Surface residues
- Terminal residues – presence of terminal residues in plants/crops produces at harvest is of great concern
- Penetrated residues
- Bound residues – residues of remaining in soil/plants after exhausting solvent extraction significance bound residues: bioavailability toxicity and accumulation nature
- Dislodgeable residues – amount of pesticide residues that can be dislodged from the two sided foliar surface of a plant during a well-defined producer which are deposited on and remain on surface after pesticide application.

### 2.1 Residues

“The amount of insecticide left over after a lapse of time.”

Disappearance of pesticide residue takes place by two way i.e.

- Dissipation: In which the disappearance of the residue is fast
- Persistence: In which there is a slow decrease in amount of residue

Ability of a pesticide to remain present and active for a long times. Provides for long-term pest control, but may harm sensitive plants and animals. May lead to illegal residues on rotational crops. Pesticide persistence often is expressed in terms of half-life. This is the length of time required for one-half of the original quantity to break down.

### 2.2 Based on these 3 Types

- Non-persistent pesticides: <30 days
- Moderately persistent pesticides: 30 to 100 days
- Persistent pesticides: >100 days.

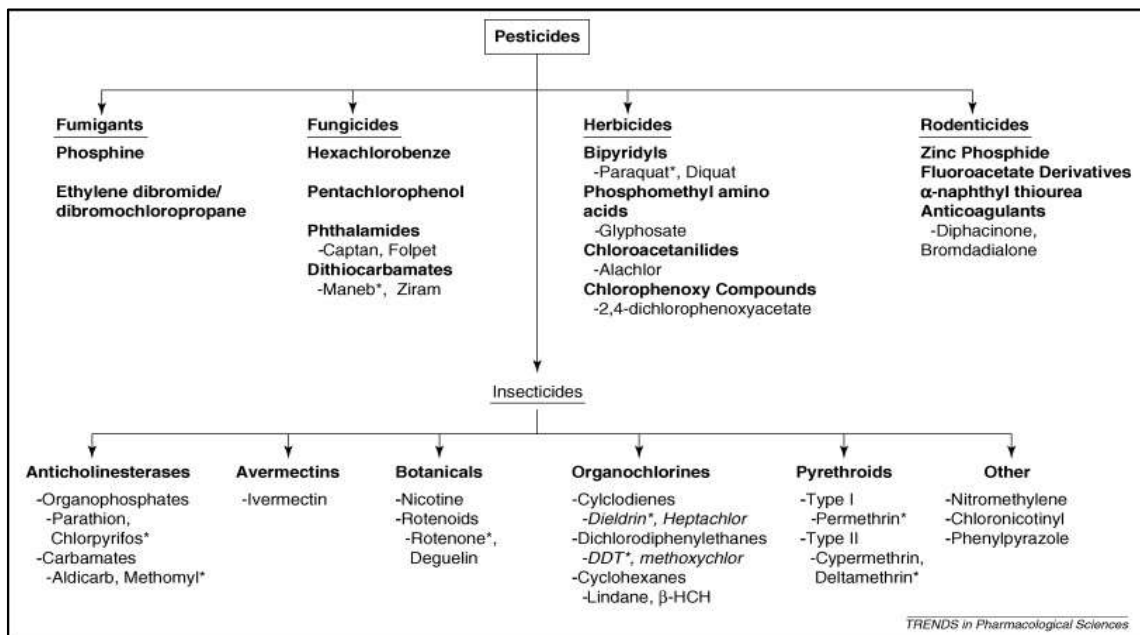

Image 2. Classification of pesticides



Image 3. Insecticide Exploration

Bhopal's pesticide plant was built in 1969 to manufacture Sevin- Asia to kill beetles, weevils and worms. The plant was operated by Union Carbide India, Limited, but an American company, Union Carbide Corporation, held > 1/2 of the stock. The leak began on December 2, 1984, when water entered a tank that was used to store methyl isocyanate, a toxic gas and a key ingredient in Sevin. The water reacted with the gas, causing extreme pressure and heat that possibly caused the tank to explode. The tank spewed 40 tons of poisonous gas into the air [5]. The toxic cloud was mostly methyl isocyanate, a compound that can irritate the throat and eyes, cause chest pain and shortness of breath, and, in large doses trigger convulsions, lung failure and cardiac arrest. The UNO classifies Endosulfan as highly dangerous insect killer and banned in 62

countries. Endosulfan, a highly toxic organochlorine pesticide was sprayed in the cashew plantations in Kasaragod District since 1976, till 2001 regularly three times every year [6].

### 2.3 Adsorption

Adsorption is the binding of pesticides to soil particles. The amount a pesticide is adsorbed to the soil varies with the type of pesticide, soil moisture, soil pH and soil texture. Pesticides are strongly adsorbed to soils that are high in clay or organic matter. They are not strongly adsorbed to sandy soils. Most soil-bound pesticides are less likely to give off vapours or leach through the soil.

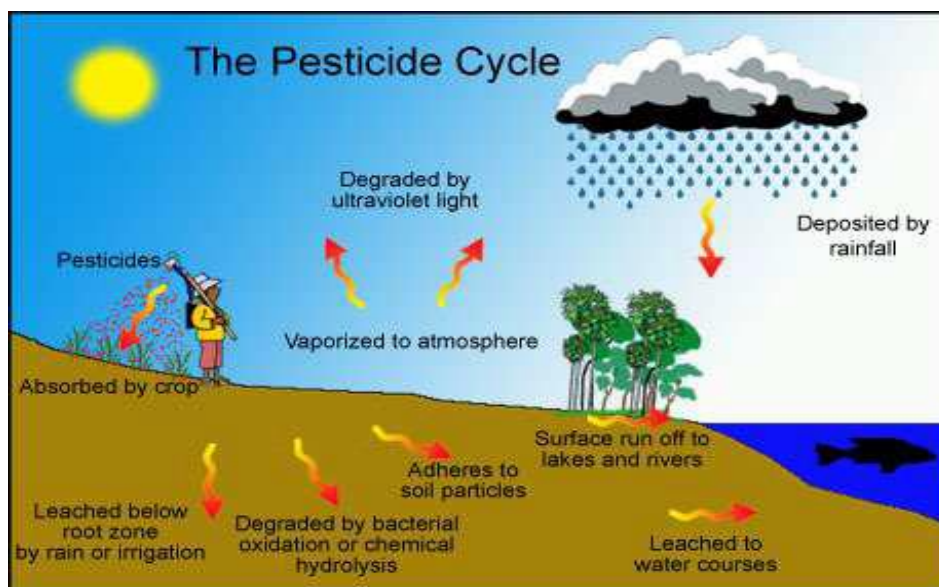

Image 4. Pesticide cycle

## 2.4 Volatilization

Volatilization is the process of converting solids or liquids into a gas, which can move away from the initial application site. Pesticides volatilize most readily from sandy and wet soils. Hot, dry or windy weather and small spray drops increase volatilization. Incorporation of the pesticide into the soil can help reduce volatilization.

## 2.5 Spray Drift

Spray drift is the airborne movement of spray droplets away from a treatment site during application

- Droplet size – smaller- more likely they will drift.
- Wind speed – stronger- more pesticide spray will drift.
- Distance between nozzle and target plant or ground.

Drift may also be hazardous to people, domestic animals, pollinating insects.

## 2.6 Runoff

Runoff is the movement of pesticides in water over a sloping surface. The pesticides are either mixed in the water or bound to eroding soil. Runoff can also occur when water is added to a field faster than it can be absorbed into the soil. Runoff from areas treated with pesticides can pollute streams, ponds, lakes and wells pesticide residues in surface water can harm animals and contaminate groundwater.

## 2.7 Absorption

Uptake of pesticides and other chemicals into plants or microorganisms. Pesticide residues may be broken down or remain inside the plant or animal, when the animal dies or as the plant decays released back. Some pesticides stay in the soil long enough to be absorbed by plants grown in a field years later. They may damage or leave residues in future crops.

## 2.8 Degradation (Breakdown Processes)

Microbial breakdown is the breakdown of chemicals by microorganisms such as fungi and bacteria. Chemical breakdown is the breakdown

of pesticides by chemical reactions in the soil. Photo degradation or Photolysis is the breakdown of pesticides by sunlight. All pesticides are susceptible to photo degradation to some extent. Hydrolysis: water also degrades pesticides by dividing large molecules into small.

## 3. METHODS FOR PESTICIDE RESIDUE ANALYSIS IN SOIL

### 3.1 Steps Involved

- Sampling
- Sample preparation
- Extraction
- Clean up
- Identification and Quantification

### 3.2 Sampling

- Previous history
- character of the sample
- Application of insecticide
- Formulation of insecticide
- Storage of samples

### 3.3 Extraction

Extraction is the process by which toxicant is transferred from the treated bulky matrix material into a solvent.

#### Types:

- Liquid liquid extraction
- Soxhlet extraction
- Automated soxlet extraction
- Super-critical fluid extraction
- Solid phase extraction
- Solid phase micro extractions
- Accelerated solvent extraction
- Microwave assisted extraction
- QuEChERS technique

**Solvents:** Water, acetonitrile, ethyl acetate, methanol, acetone and n-hexane.

### 3.4 Clean-Up

#### Different Clean – up methods are:

- Liquid - Liquid Partitioning: Dimethylformamide, hexane (lipids)
- Column Chromatography: florisil, alumina and silica (carotenoids, ES)

- Solid Phase Extraction: carbon C-8, C-18 (organic acids and colloids)
- Chemical clean up: H<sub>2</sub>SO<sub>4</sub> and chromic acid (lipids, ES, H<sub>2</sub>SO<sub>4</sub>-robust organochlorines)
- Gel permeation / Size Exclusion Chromatography: (lipids, proteins)
- Sweep co-distillation: hexane, diethyl ether (groups of OCs)

### 3.5 Identification and Quantification

- Gas – Liquid Chromatography
- High – performance Liquid Chromatography
- GLC coupled with Mass – Detector (GC–MS or GC-MS<sup>n</sup>)
- HPLC coupled with Mass Detector (LC-MS or LC-MS<sup>n</sup>)

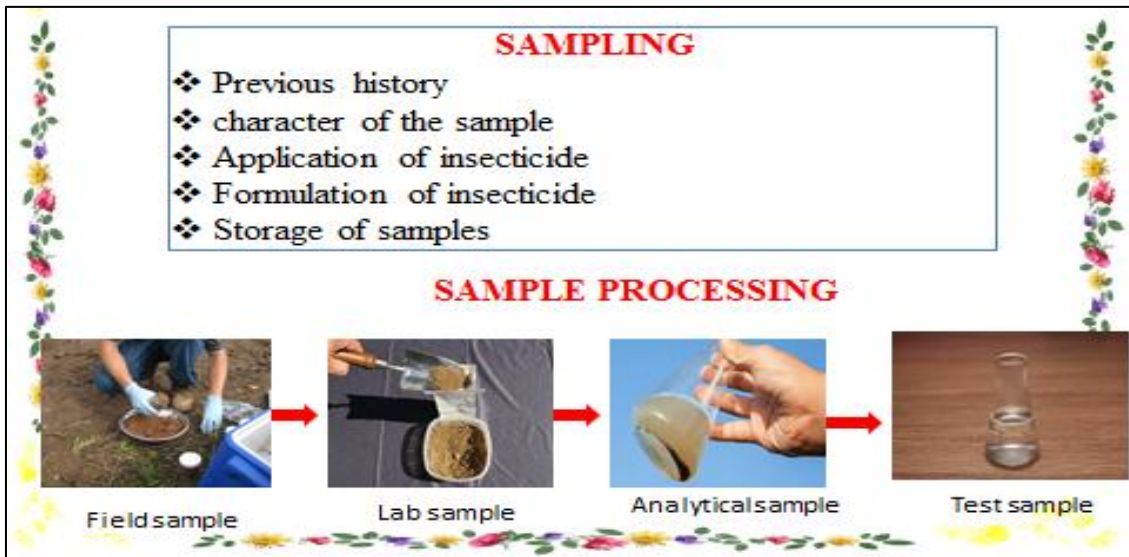

Image 5. Methods for pesticide residue analysis in soil

Gas – Liquid Chromatography (GLC / GC):

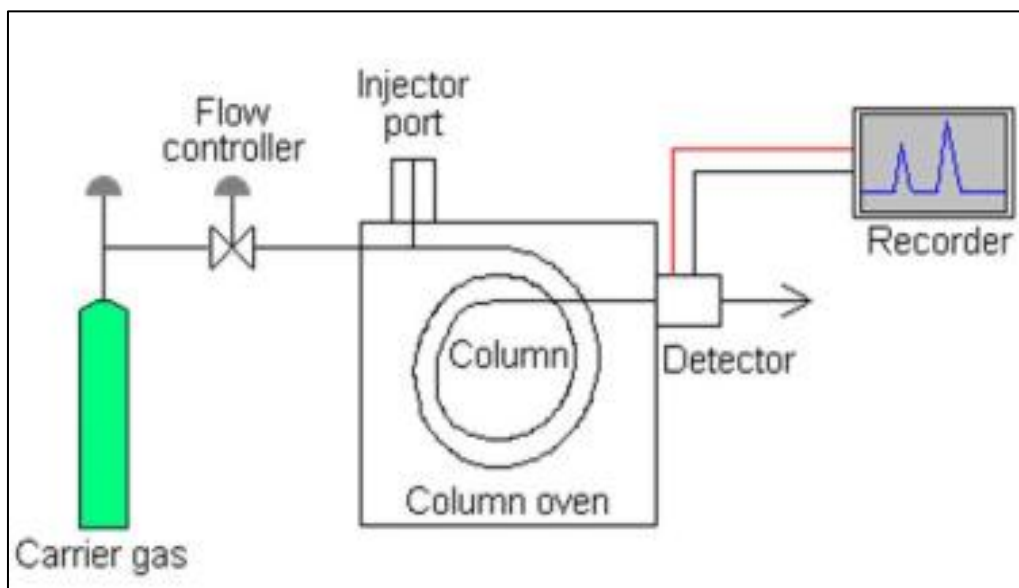

Image 6. Principles of Gas chromatograph

A gas chromatograph is a chemical analysis instrument that is used to separate chemicals in a complex sample. The mobile phase in gas-liquid chromatography is a non-reactive gas such as nitrogen (the carrier gas), and the stationary phase is a small amount of a non-volatile liquid held on a finely divided inert solid support [7]. The distribution principle underpins gas-liquid chromatography. GLC fractionates the components of vaporised samples by partitioning between a gaseous mobile phase and a liquid stationary phase that remains in the column (specify reference). The various components of a sample mixture are formed and separated according to their distribution as the vapours of the sample mixture move between the stationary phase (liquid) and the mobile phase (gas).

In gas-liquid chromatography, the mobile phase is a non-reactive gas such as nitrogen (the carrier gas) and the stationary phase consists of a small amount of a non-volatile liquid held on a finely divided inert solid support Gas-liquid chromatography is based on the distribution principle. In GLC, the components of the vaporized samples are fractionated due to partitioning between a gaseous mobile phase and a liquid stationary phase that remains in the column(specify reference) . .As the vapors of the sample mixture move between the stationary phase (liquid) and the mobile phase (gas), the various components of a sample mixture are formed separated according to their distribution

coefficient between gaseous and liquid stationary phase.

**Instrumentation:**

- Tank of carrier gas
- Flow regulator and flow meter
- Injection port
- Column
- Temperature controlled device
- Detector
- Microprocessor/recorder

**3.6 The Mobile Phase (Carrier Gas)**

A neutral gas, such as N<sub>2</sub> or He. Function is to move the sample vapors through the column without interacting chemically with the sample. Typical parameters. Column inlet pressure: 10 to 50 psi (above ambient).Flow rate: 25 to 50 mL/min (packed column).Precise control of the carrier gas flow rate is essential to obtaining repeatable retention times.

**3.7 Sample Injection**

Sample is injected into a stream of hot mobile phase using a syringe. The sample vaporises at high temperatures (at least 50oC above the boiling point of the sample). Creates a thin plug of sample vapour that is introduced onto the column. You should inject 1 to 5 mL of sample onto packed columns. A split valve is used to introduce a tiny portion of the material onto capillary columns.

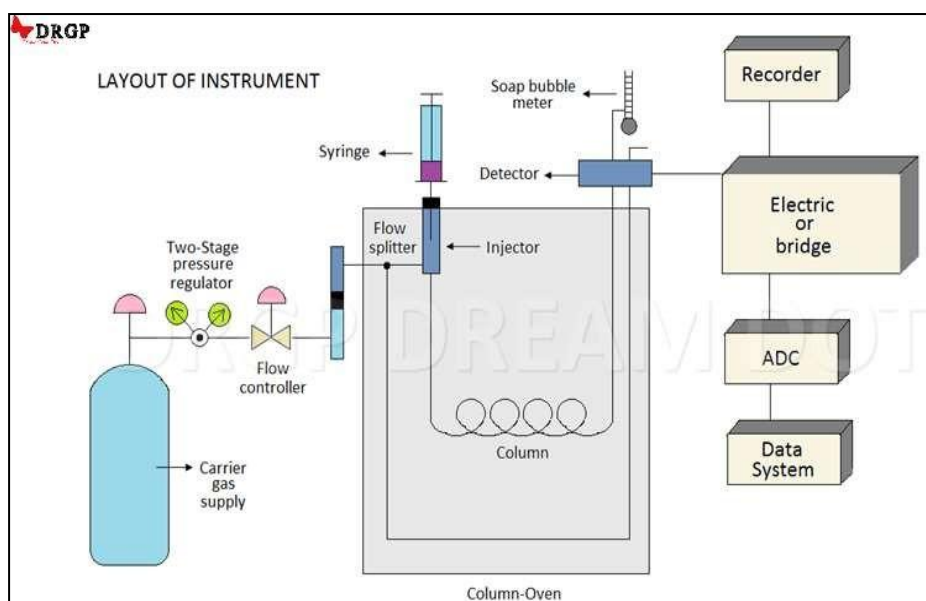

**Image 7. Instrument layout**

### 3.8 Columns

The column, which controls the separation efficiency, is the brain of the GC. It is constructed of copper or glass. There are two different sorts of columns, depending on their purpose: analytical columns have a length of 1-2 metres and an outer diameter of 3-6 millimetres, while preparatory columns have a length of 3-6 metres and an outer diameter of 6-9 millimetres.

### 3.9 Column Oven

Controlling the column temperature precisely. The temperature of the column should be just below the solutes' boiling points (but above the dew point; i.e., no condensation). Use programmable temperature for complex combinations with a wide range of boiling points. Reproducible retention times require precise temperature control in the oven.

### 3.10 Detectors

Generate an electrical signal proportional to solute concentration or mass flow rate. A detector provides specific response for the separated components. Majority of the organic compound applications require flame ionization detector.

#### Ideal characteristics:

- High sensitivity
- Rapid response time

- Non-destructive technique
- Applicable to wide range of samples
- Easy to use
- Stable, predictable response

#### Types of Detectors in Gas Chromatography:

- Flame ionisation detector
- Thermal conductivity detector
- Electron capture detector
- Flame photometric detector
- Photo ionisation detector
- Nitrogen phosphorus detector

#### Thermal conductivity detector:

- Element is electrically heated at constant power.
- Temperature depends on thermal conductivity of surrounding gas.
- Measure conductivity with respect to a reference.
- When analyte comes off, filament temperature goes up, resistance goes down.

### 3.11 Mechanism

A detector cell contains a heated filament with an applied current. As carrier gas containing solutes passes through the cell, change in the filament current occurs. The current change is compared against current in reference cell. The difference is measured and a signal is generated.

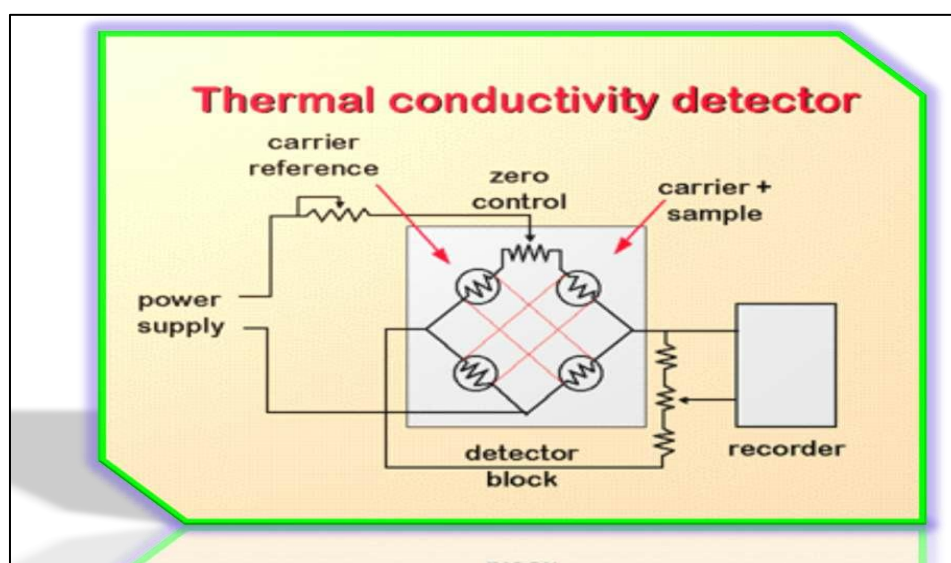

Image 8. Thermal conductivity detector



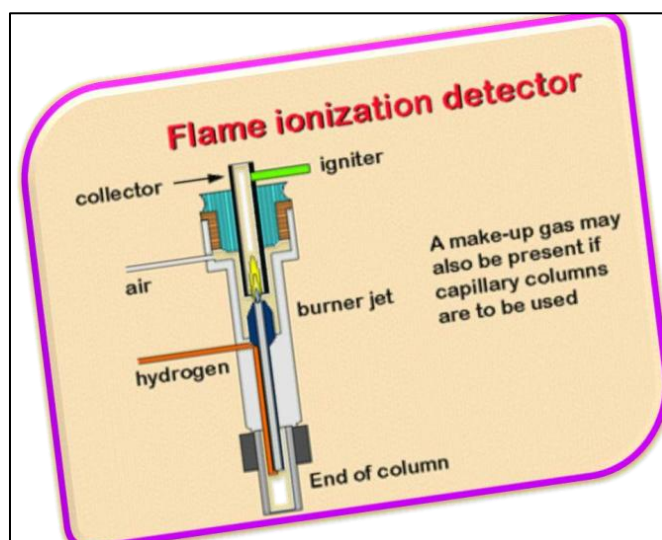

Image 9. Flame Ionization Detector

- **Sensitivity:** 5-20 ng
- **Selectivity:** All compounds
- **Gases:** Hydrogen, Helium
- **Temperature:** 150-250°C

#### Flame Ionization Detector

- Column effluent is passed through a H<sub>2</sub>-air flame produces ions and electrons.
- Charged particles are accelerated by voltage applied between jet and collector - results in current
- Less sensitive to non-hydrocarbon groups

#### 3.12 Mechanism

Compounds are burned in a hydrogen-air flame. Carbon containing compounds produce ions that are attracted to the collector. The number of ions hitting the collector is measured and a signal is generated

- Sensitivity: 0.1-10 ng
- Selectivity: compounds with C-H bonds
- Gases: combustion- hydrogen and air, makeup-He, N<sub>2</sub>
- Temperature: 250-300°C

#### Electron capture detector:

- Carrier gas (and analyte) passes over β-emitter, resulting in ionization and electron production
- Produce current between electrodes
- Most commonly used for halogenated organics

#### 3.13 Mechanism

Electrons are supplied from a <sup>63</sup>Ni foil lining the detector cell. A current is generated in the cell. Electronegative compounds capture electrons resulting in a reduction in the current. The amount of current loss is indirectly measured and a signal is generated:

- Sensitivity: 0.1-10 ng
- Selectivity: Halogens, nitrates
- Gases: Nitrogen or argon
- Temperature: 300-400°C

#### 3.14 Recorder

Recorder is a device that draws the chromatogram that results from a chromatographic process onto chart paper. The device can have a full scale deflection (FSD) voltage that commonly ranges from 1 mv to 10v. The time scale of the chart movement normally ranges from about 1 cm per second to 1 cm per hour.

#### 3.15 Advantages of GLC

It is important to do both qualitative and quantitative analysis. Pesticide analysis. Quantitative information based on peak regions. Simple instrument, quick analysis time. High sensitivity. The method is applicable to around 60% of organic chemicals. Very tiny sample quantities can be used. Determination of various cosmetics and perfumes. analysis of petroleum products, gasoline, waxes, etc. determination of

water in creams, ointments, and pastes. isolation and identification of medications or metabolism in urine plasma, serum.

the molecules flowing past it. This allows a much better separation of the components of the mixture.

### 3.16 High – performance Liquid Chromatography (HPLC)

High performance liquid chromatography is basically a highly improved form of column chromatography. Instead of a solvent being allowed to drip through a column under gravity, it is forced through under high pressures of up to 400 atmospheres. That makes it much faster. It also allows you to use a very much smaller particle size for the column packing material which gives a much greater surface area for interactions between the stationary phase and

High-performance liquid chromatography (HPLC- formerly referred to as high-pressure liquid chromatography) is a technique in analytical chemistry used to separate, identify, and quantify each component in a mixture. It relies on pumps to pass a pressurized liquid solvent containing the sample mixture through a column filled with a solid adsorbent material. Each component in the sample interacts slightly differently with the adsorbent material, causing different flow rates for the different components and leading to the separation of the components as they flow out of the column.

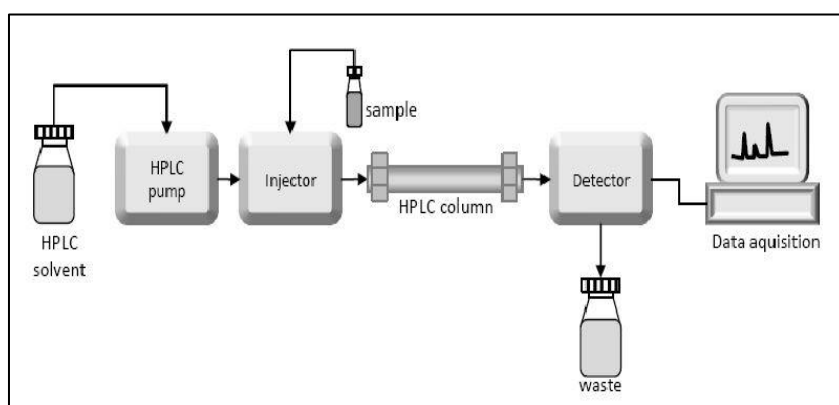

Image 10. High performance Liquid Chromatography (HPLC)

### 3.17 GLC coupled with Mass – Detector (GC–MS)

Separation based on mass to charge ratio of the particles/substances

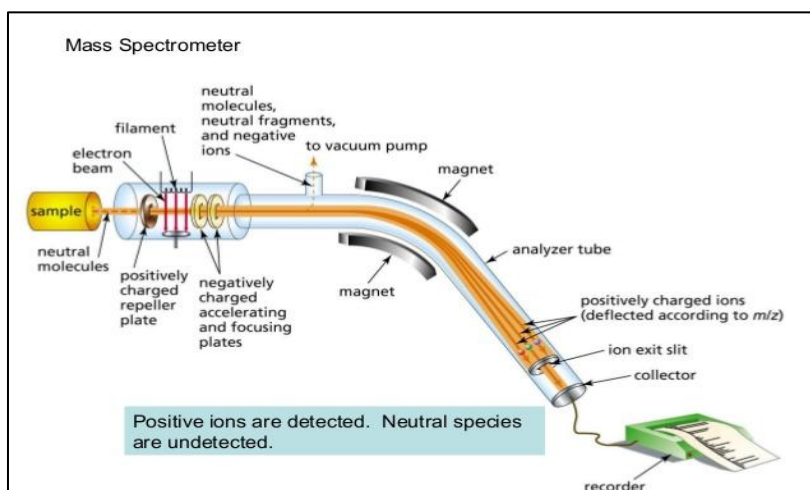

Image 11. GLC coupled with Mass – Detector (GC–MS)

### 3.18 HPLC coupled with Mass – Detector (GC–MS)

Separation by liquid chromatography and Quantification based on mass to charge ratio of the particles / substances.

#### Determination of Organophosphorus Pesticides in Soil by Dispersive Liquid Liquid Microextraction and Gas Chromatography

Zhonghua et al. [8] experimental study in Beijing, China on Fast and sensitive sample pretreatment technique for determination of organophosphate pesticides (OPP) in soil samples is developed

using dispersive liquid-liquid microextraction (DLLME) in combination with Gas Chromatography-Flame Photometry Detection. The experimental conditions, including the type of extracting and dispersing agent and their volumes, the extraction time and the addition of salt are examined and the following experimental factors are used: 20 ml chlorobenzene as extraction solvent; 1.0 ml acetonitrile as a dispersing solvent; no added salt; and an extraction time of 1 min. Under optimal conditions, the linearities for the three target OPPs (Ethoprophos, Chlorpyrifos and Profenofos) are obtained at five points in the concentration range of 2.5-1500 mg/kg, and three replicates are used for each point.

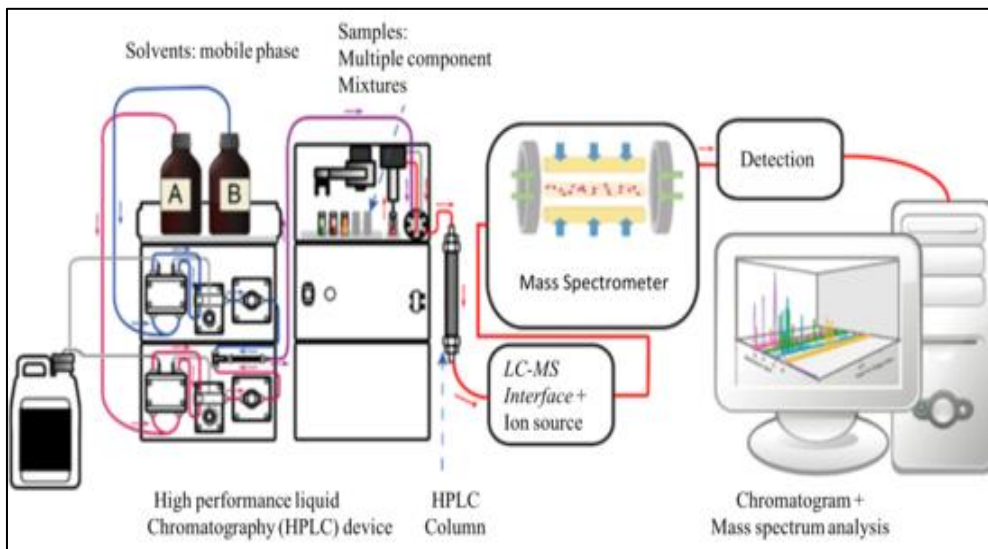

Image 12. HPLC coupled with Mass – Detector (GC–MS)

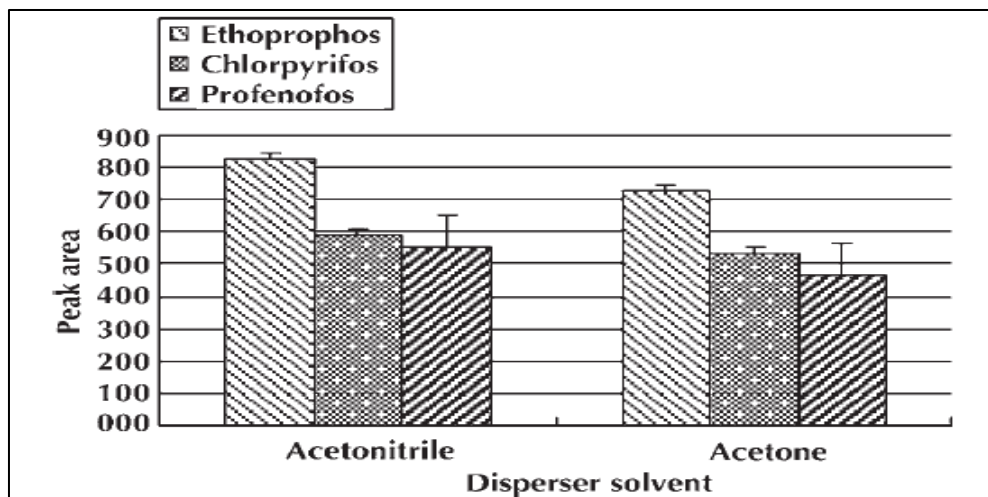

Fig. 1. The effect of disperser solvent on DLLME

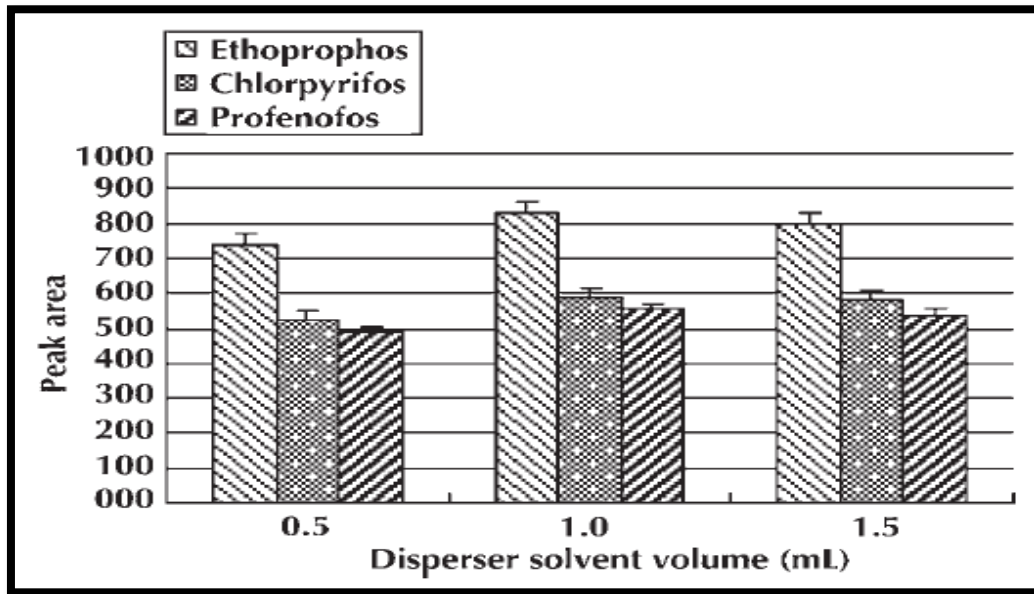

Fig. 2. Effect of the disperser solvent volume on DLLME

For a DLLME method, the disperser solvent must play two roles. Firstly, it must efficiently extract analytes from soil samples. Secondly, it must be used as a disperser solvent in the DLLME step. The selection of the disperser solvent is based on its miscibility with both the organic and the aqueous phase. MeCN and acetone were the most used solvents for the extraction of OPPs from the samples; all of them have demonstrated acceptable recoveries [9]. In view of these considerations, MeCN and acetone were evaluated for this study. A series of sample solutions were investigated by using 1.0 mL each of the disperser solvents containing 20.0 mL chlorobenzene. As shown in (Fig. 1), the best extraction efficiencies were obtained when MeCN was used as a disperser solvent. Hence, MeCN was selected.

The effect of the disperser solvent volume was investigated by using different volumes of HPLC-grade acetonitrile (0.50, 1.0, and 1.5 mL) containing 20 mL chlorobenzene. The results shown in (Fig. 2) demonstrate that the extraction efficiencies increased by increasing the volume of acetonitrile at first and then decreased with further increase of the acetonitrile volume; this phenomenon may be attributed to the fact that at a low volume of acetonitrile, a cloudy state is not well formed. Based on the experimental results, 1.0 mL acetonitrile was chosen for the subsequent study.

#### Method development for pesticide residue analysis in farmland soil using High Performance Liquid Chromatography

Marselina et al. [10], Experiment conducted in Bumiaji Subdistrict, Batu City, Malang. A method for the determination of diazinon and chlorantraniliprole in soil samples was developed. The analyte was extracted with acetonitrile from a soil sample from farmland. The determination and quantification of diazinon and chlorantraniliprole were performed by high performance liquid chromatography (HPLC) with a UV detector. Several parameters of the HPLC method have been optimized for sensitivity, high separation resolution and accurate determination of diazinon and chlorantraniliprole. The optimal conditions for the separation of two pesticides were the composition of the acetonitrile eluent: water ratio of 60:40, 0.4 ml/min flow rate and 220 nm wavelength.

The chromatogram of diazinon and chlorantraniliprole separation resulted in four variations of acetonitrile:water composition can be seen in (Fig. 3) that the more acetonitrile solvent used, the faster the retention time of the compound. This was caused by nonpolar columns and polar solvents so that the more non-polar compounds would be retained longer in the column. At 60:40 of mobile phase compositions, both compounds separated well at the retention time of each compound, chlorantraniliprole 9.8 and diazinon 18.64 and a short retention time of fewer than 20 minutes.

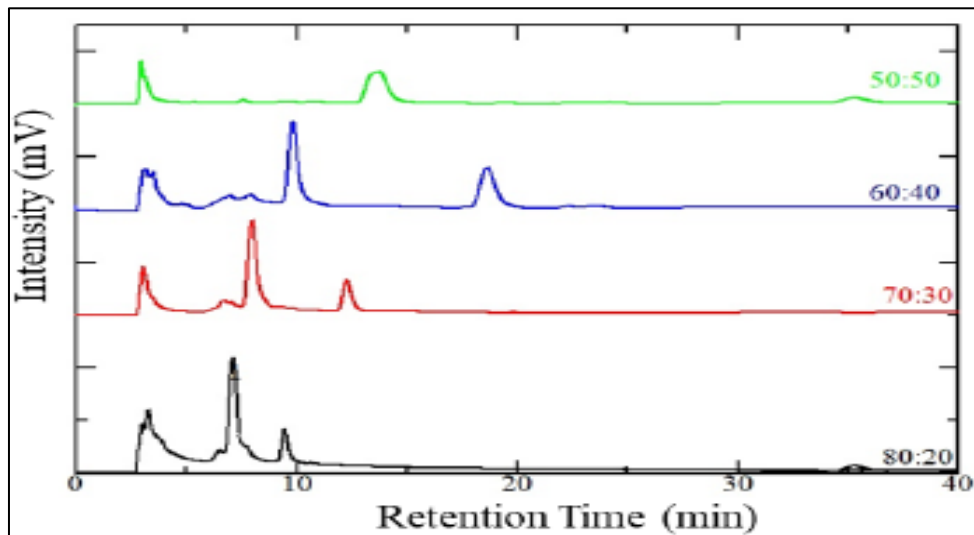
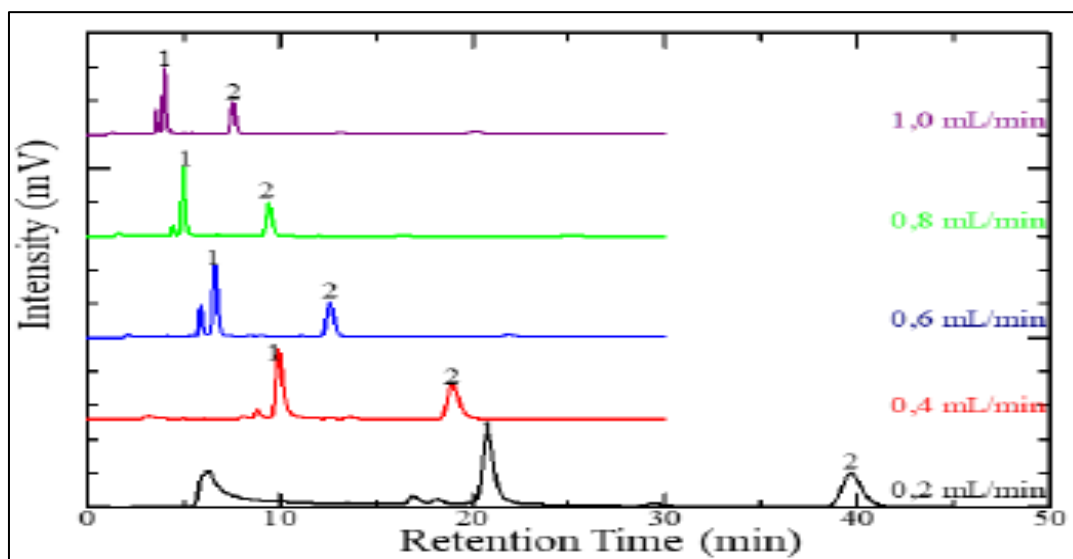

**Fig. 3. Chromatogram Standard of Chlorantraniliprole and Diazinon (effect of extraction volumes on retention time)**

The chromatogram of diazinon and chlorantraniliprole separation resulted in four variations of acetonitrile: water composition can be seen in (Fig. 4) that the more acetonitrile solvent used, the faster the retention time of the compound. This was caused by nonpolar columns and polar solvents so that the more non-polar compounds would be retained longer in the column. At 60:40 of mobile phase compositions, both compounds separated well at the retention time of each compound,

chlorantraniliprole 9.8 and diazinon 18.64 and a short retention time of fewer than 20 minutes.

Faster the flow rate caused smaller standard peak area. So it may be determined the optimum flow rate conditions for the separation of diazinon and chlorantraniliprole was 0.4 mL/min. Where the fast analysis time is below 20 minutes and the large peak compound area was 550134 for chlorantraniliprole and 427586 for diazinone.



**Fig. 4. Effect of the flow rate on the retention time of chlorantraniliprole and diazinon compounds**

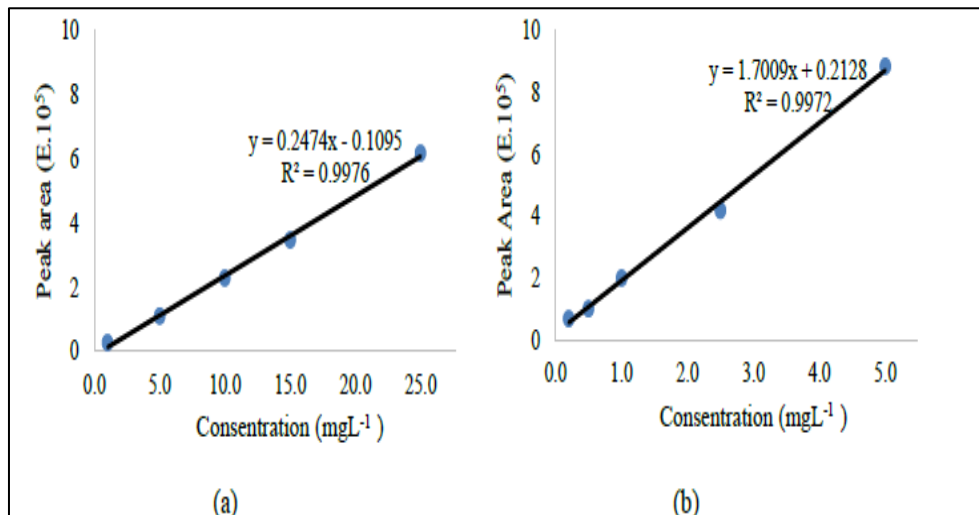

**Fig. 5. Standard Curve Diazinon (a) and Chlorantraniliprole (b)**

Standard curve diazinon and chlorantraniliprole may be seen in (Fig. 5). Method validation obtained diazinon linearity was in the range from 1-25 mgL<sup>-1</sup> with R2 of 0.9976, 1.19 mgL<sup>-1</sup> LOD, and 3.98 mgL<sup>-1</sup> LOQ; whilst the linearity of chlorantraniliprole was in the range from 0.2-5 mgL<sup>-1</sup> with R2 of 0.9972, 0.39 mgL<sup>-1</sup> LOD, and 1.29 mgL<sup>-1</sup> LOQ. When the method was applied to the soil sample, both pesticides showed acceptable recoveries for real sample of more than 85%. thus, the developed method met the validation requirement.

#### 4. CONCLUSION

A critical comparison is made between the proposed subcritical water extraction and the traditional Soxhlet extraction method, the analysis time is reduced from 20 hours to less than 2 hours, and the organic solvent used in the extraction procedure can be used on be reduced by less than 2 percent. Dispersive liquid-liquid microextraction offers good repeatability, recovery and has the advantage of simplicity, speed and reduced consumption of organic solvents. The detection and determination limits of the gas chromatography mass spectrophotometers achieved with this method allow it to be used in the monitoring of pesticide residues in soil. A simple, fast and sensitive DLLME method in combination with GC-FPD was developed for the determination of OPP in soil samples. Compared to traditional methods, DLLME offers good repeatability, recovery and has the advantage of simplicity, speed and reduced consumption of organic solvents.

#### ACKNOWLEDGEMENT

The authors are grateful to Dr. Gurumurthy K. T., for their warm reception and support during the study.

#### COMPETING INTERESTS

Authors have declared that no competing interests exist.

#### REFERENCES

1. Mathur SC. Future of Indian pesticides industry in next millennium. Pesticide Information. 1999; 24(4):9–23.
2. Mathur S, Tannan S. Future of Indian pesticides industry in next millennium. Pestic. Inf. 1999;24:9–23.
3. FAO, Pesticide use data-FAOSTAT; 2018. Available: <http://www.fao.org/faostat/en/#dataRp>
4. WORLDATLAS; 2018. Available: <https://www.worldatlas.com/articles/top-pesticide-consuming-countries-of-the-world.html>
5. Eckerman. The Bhopal Saga—Causes and Consequences of the World's Largest Industrial Disaster. India: Universities Press; 2005. DOI:10.13140/2.1.3457.5364. ISBN 978-81-7371-515-0.
6. Frederick Noronha, IndiaENews.com, July 5th, accessed July 5th. Ministry of Chemical; 2007. Available: [www.chemical.nic.in](http://www.chemical.nic.in)

7. Ettre, Leslie S. Chapters in the evolution of chromatography. London: Imperial College Press; 2008. ISBN 1860949436.
8. Zhonghua Y, Yu LIU, Donghui LIU, Zhiqiang Z. Determination of organophosphorus pesticides in soil by Dispersive Liquid–Liquid Microextraction and Gas Chromatography. J. Chromatographic Sci. 2012;50:15–20.
9. Anastassiades M, Lehotay SJ, Stajnbaher D, Schenck FJ. Fast and easy multiresidue method employing acetonitrile extraction/partitioning and “dispersive solid-phase extraction” for the determination of pesticide residues in produce. J. AOAC Int. 2003;86:412–431.
10. Marselina TDT, Akhmad S, Hermin S. Method development for pesticide residue analysis in farmland soil using High Performance Liquid Chromatography. International Conference on Chemistry and Material Science (IC2MS); 2017.

© 2022 Naik and Gurumurthy; This is an Open Access article distributed under the terms of the Creative Commons Attribution License (<http://creativecommons.org/licenses/by/4.0>), which permits unrestricted use, distribution, and reproduction in any medium, provided the original work is properly cited.

*Peer-review history:*

*The peer review history for this paper can be accessed here:  
<https://www.sdiarticle5.com/review-history/92905>*