



# Performance Evaluation of Maize Cob Harvester in Chhattisgarh, India

Shalini Garudik <sup>a++\*</sup>, R. K. Naik <sup>a#</sup>, Kanhaiya Thakur <sup>at</sup>  
and Geeta Patel <sup>at</sup>

<sup>a</sup> Department of Farm Machinery and Power Engineering, SV CAET& RS, IGKV, Raipur,  
(Chhattisgarh), India.

## Authors' contributions

This work was carried out in collaboration among all authors. All authors read and approved the final manuscript.

## Article Information

DOI: 10.9734/IJPSS/2023/v35i244309

## Open Peer Review History:

This journal follows the Advanced Open Peer Review policy. Identity of the Reviewers, Editor(s) and additional Reviewers, peer review comments, different versions of the manuscript, comments of the editors, etc are available here: <https://www.sdiarticle5.com/review-history/107546>

Original Research Article

Received: 17/08/2023

Accepted: 21/10/2023

Published: 30/12/2023

## ABSTRACT

Maize is one of the vital crops after rice and wheat in India and is a widely produced cereal. Maize contributes only 2.4 percent of total world production. Maize occupied 22.98 lakh hectares, with a production of 36.61 MT in India. The average yield per hectare during 2020- 21 was 2804 kg per hectare. The performance of the maize cob harvester was tested to know the effect of three independent parameters like forward speed of operation (1.7 km/h, 1.9 km/h, 2.1 km/h), snipper speed (55 m/min, 62 m/min, 68 m/min), Variety of maize crop (Dhania- 9965, Sartaj-765, D-9081) on different dependent parameters like stripping loss, ratio of stem length before and after harvesting and machine parameter like actual field capacity, field efficiency. It was also observed that the machines work satisfactorily at forward speed 1.9 km/h and snipper speed 62 m/min. crop parameters stripping losses 0.197%, ratio of length of stem before and after harvesting are 825 mm and 113.33 mm and machine parameter actual field capacity is 0.081 ha/h, field efficiency 75.7%. The cost of operation of machine was found as Rs.337.65 per hour, breakeven point was found as 149.64 h and payback period was 2.5 years (approx.) The total output of machine is 75 q/ha.

<sup>++</sup>M.Tech. Scholar;

<sup>#</sup>Professor;

<sup>†</sup>Ph.D. Scholar;

<sup>\*</sup>Corresponding author: E-mail: shalinigarudik33@gmail.com;

**Keywords:** Maize cob harvester; stripping loss; snipper speed; field efficiency; stem length; length of cut (stalk).

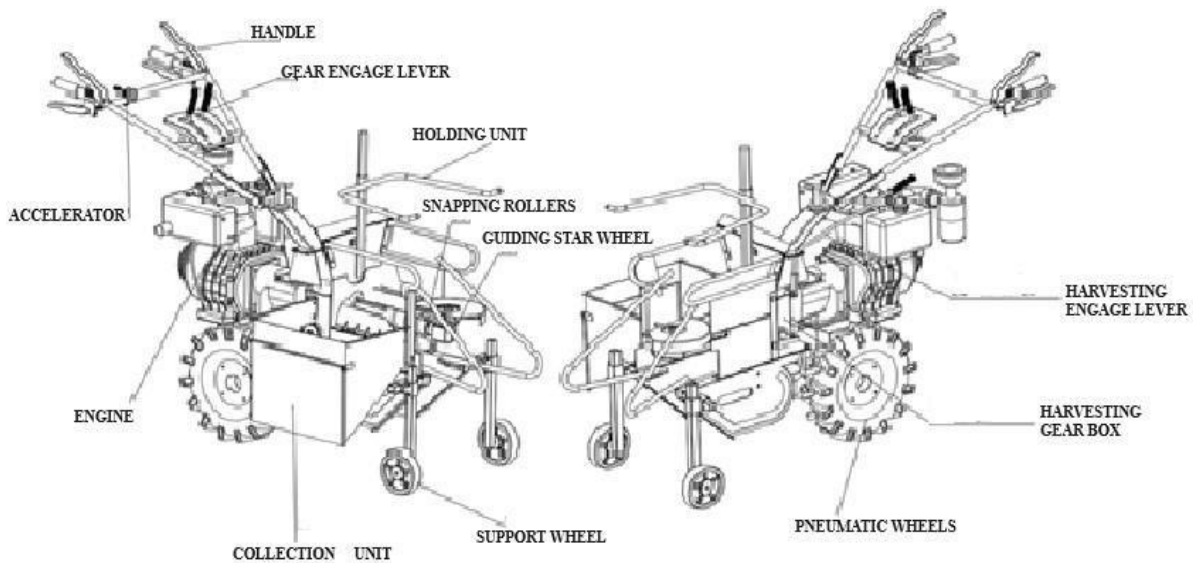
## 1. INTRODUCTION

Maize is a native crop of America. During the 17th century, Portuguese traders introduced it to India. It is grown during the entire year in various parts of the country. The main growing season in northern India is the kharif (monsoon) season. But since the environment is warm at every year, maize can be planted there anytime during April and October. The optimal temperature for germination is 21°C, and the ideal temperature for growth is 32°C. It rises in height from sea level to 3000 metres. It can also be grown on a variety of climatic conditions (Anonymous, 2021-22). Maize (*Zea mays L.*) is a coarse cereal and is the staple food in many developed countries. It is also an important input for many industrial products [1-3]. The area under maize in India is 23.10 million tonnes with productivity of 19.89 million tonnes (Anonymous, 2022-23). The area and production under maize is just after the area of paddy in Chhattisgarh in *Kharif* season [4-6]. It used 0.206 million hectares of land in *Kharif* 2020-21 and produced 5.76 t/ha. (Anonymous, 2022). The Baster Plateau (Baster, Bijapur, Dantewada, Sukma, Kondagaon, Kanker), the Chhattisgarh plain (Durg, Rajnangoen, Gariyaband), and the Northern hilly regions of the state are where maize is primarily grown (Korea, Korba, Surajpur, Balrampur, and Sarguja districts). Small size maize cob harvester is an

essential machine to reduce the cost of harvesting and to reduce the drudgery. Maize harvesting machine is the small type of corn cob harvester, the machine can work single row corn, the machine can work with tiller and walk tractor supporting the collection of the bucket is full, we can take off the filling beg, the height of stay is adjustable, the tension clutch work safely, and the turning radius is small [7-9]. The corn harvesting machine can harvest corns and crush straws at the same time. The corn straws are grinded directly as fertilizer for the field. The harvester will also help in drudgery reduction, cost reduction and time consumption [10-13].

## 2. MATERIALS AND METHODS

The experiments on performance evaluation of the maize cob harvester were conducted in the field under different forward speeds. The evaluation was conducted at Agronomy Field, IGKV, Raipur in the month of April and May, 2023. Three different variables were selected viz. variety of maize crop, forward speed of operation and snipper speed (rolling speed) denoted by V, F and S respectively with three levels of each factor. The details about the independent parameter and dependent parameters for the studies was presentation in Table 1. Observed data were analysed by using factorial randomized block design.



**Fig. 1. Component of maize cob harvester**

**Table 1. Different independent and dependent parameter for the performance evaluation of maize cob harvester**

| S. NO. | Independent parameters |        | Dependent parameters |  |
|--------|------------------------|--------|----------------------|--|
|        | Factors                | Levels |                      |  |
| 1.     | Variety (V)            | a)     | Dhania-9965          | Crop parameters<br>a) Stripping loss, (%)<br>b) Length of stem before and after harvesting, (mm) |
|        |                        | b)     | Sartaj-765           |  |
|        |                        | c)     | D-9081               |  |
| 2.     | Forward speed (F)      | a)     | 1.7 km/h             |  |
|        |                        | b)     | 1.9 km/h             |  |
|        |                        | c)     | 2.1 km/h             |  |
| 3.     | Snipper speed (S)      | a)     | 55 m/min             | Machine parameters<br>a) Actual field capacity, (ha/h)<br>b) Field efficiency, (%)               |
|        |                        | b)     | 62 m/min             |  |
|        |                        | c)     | 68 m/min             |  |

## 2.1 Independent Parameters

### 2.1.1 Variety

The different types of maize crop variety are taken to test and performance evaluation of the machine. The maize crop variety under different size of cob length are Dhania-9965, Sartaj- 765 and D-9081 were large, medium and small size of cob variety respectively.

### 2.1.2 Forward speed

The three forward speeds were selected for the study i.e.1.7, 1.9 and 2.1 km/h which were available under field working of machine when operated at low and high gears with different throttle positions.

### 2.1.3 Snipper speed

The speed of snapping rollers increases with the machine forward speed. The peripheral speed of snapping rollers obtained for the corresponding forward speeds 1.7, 1.9 and 2.1 km/h were 55, 62 and 68 m/min, respectively.

## 2.2 Dependent Parameters

### 2.2.1 Stripping loss

The stripping loss of maize cobs is number of cobs losses (damaged) in harvesting. The stripping loss is calculated by total number of cobs in plant in one row before harvesting to the total number of cobs after harvesting.

$$\text{Stripping loss (\%)} = ((S1 - S2) / S1) \times 100$$

Where,

S1 = Number of cobs in plant in one row before harvesting.

S2 = Number of cobs after harvesting.

### 2.2.2 Length of stem before and after harvesting

In before harvesting the length of maize stem is the distance between the tassel branches to the base of the plant on the ground and after harvesting the length of maize stem is the distance between the top of cut edge of stem to the base of the plant on ground.

### 2.2.3 Actual field capacity

The effective/actual field capacity was determined by measuring the time consumed for real work and the time lost for other activities like turning, refilling the fuel tank and for discharging the cobs from collection bin.

$$\text{Actual feild capacity, (Ha / h)} = \text{Actual area covered} / \text{Total time required to coverd area}$$

### 2.2.4 Field efficiency

Field efficiency is the ratio of effective field capacity to theoretical field capacity.

$$FE = (EFC / TFC) \times 100$$

Where,

FE = Field efficiency, %;

EFC = Effective field capacity, ha/h; and

TFC = Theoretical field capacity, ha/h.



**Fig. 2. Field testing by the machine, total cobs obtained and residue management after harvesting**

### 3. RESULTS AND DISCUSSION

The result obtained through the experiments were presented and discussed in details in the following section. The effects of various independent parameters on the performance parameters of the maize cob harvester were also discussed.

#### 3.1 Effect of Forward Speed, Snipper Speed and Different Variety, on Stripping Loss by Maize Cob Harvester

The effect of forward speed and snipper speed at different maize crop variety, on stripping losses was given in Table 2. It was observed that there is no significant effect of all three on stripping loss ( $\alpha=0.05$ ). It may be due to variety of different size of maize cob and it has no effect on the stripping losses. Fig. 3 depicts the effect of forward speed and snipper speed on stripping losses. It was found that there is significant effect of both these parameters on stripping losses. It was observed that highest at 2.1 km/h forward speed and snipper speed at 68 m/min. It may be due to higher forward speed make the higher

stripping losses at higher snipper speed. Fig. 4 Stripping losses had no significant effect of forward speed and variety. It was observed highest at 2.1 km/h forward speed and at a variety of Dhania-9965. It may be due to higher forward speed make the higher stripping losses at variety Dhania-9965 from it. Fig. 5 depicts the effect of snipper speed and variety on stripping loss . It was found that there is no significant effect of both these parameters on stripping loss. It may be due to different size of maize cob variety and it has no effects on the stripping loss.

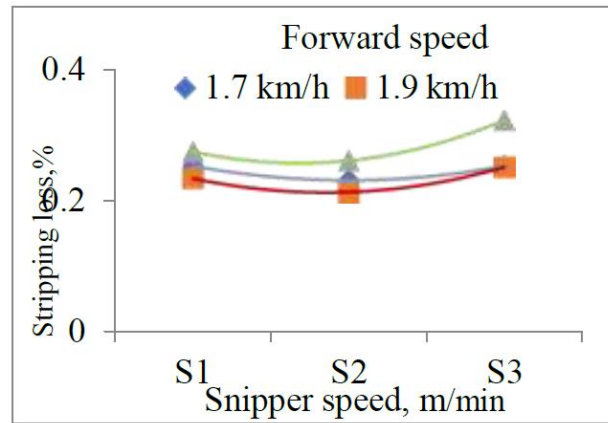
#### 3.2 Effect of Forward Speed, Snipper Speed and Different Variety, on Length of Stem before and after Harvesting by Maize Cob Harvester

The effect of forward speed and snipper speed at different maize crop variety, on length of stem after harvesting was given in Table 3. It was observed that there is significantly effect of all three on length of stem after harvesting ( $\alpha=0.05$ ). It was also observed that length of stem after harvesting was obtained as significantly highest (217 mm) at 2.1km/h forward speed, 68 m/min snipper speed and variety D-9081. In higher

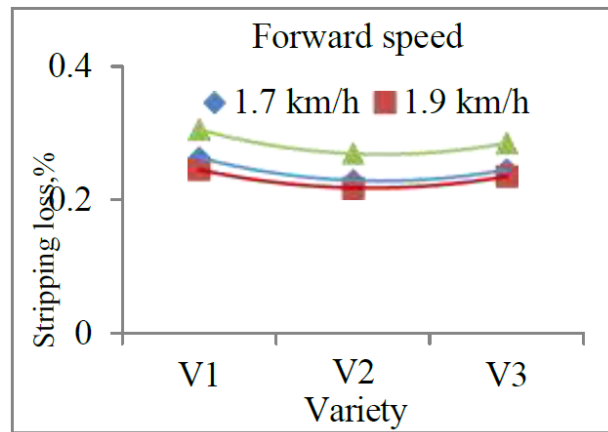
**Table 2. Effect of forward speed, snipper speed and variety, on stripping loss**

| Forward speed, (km/h)                  | Stripping loss, (%)          |       |       |                             |       |       |                             |       |       |
|--|------------------------------|-------|-------|-----------------------------|-------|-------|-----------------------------|-------|-------|
|  | F1 (1.7 km h <sup>-1</sup> ) |       |       | F2(1.9 km h <sup>-1</sup> ) |       |       | F3(2.1 km h <sup>-1</sup> ) |       |       |
| Snipper speed,(m/min)                  | S(55)                        | S(62) | S(68) | S(55)                       | S(62) | S(68) | S(55)                       | S(62) | S(68) |
| Variety                                |                              |       |       |                             |       |       |                             |       |       |
| V(Dhania-9965)                         | 0.267                        | 0.246 | 0.276 | 0.246                       | 0.225 | 0.262 | 0.291                       | 0.282 | 0.342 |
| V(Sartaj-765)                          | 0.236                        | 0.214 | 0.237 | 0.222                       | 0.197 | 0.235 | 0.263                       | 0.24  | 0.304 |
| V(D-9081)                              | 0.255                        | 0.235 | 0.245 | 0.234                       | 0.215 | 0.256 | 0.272                       | 0.262 | 0.322 |
| Factors                                |                              |       |       |                             |       |       | C.D                         | SE(d) | SE(m) |
| Forward speedx Snipper speed x Variety |                              |       |       |                             |       |       | NS                          | 0.006 | 0.005 |

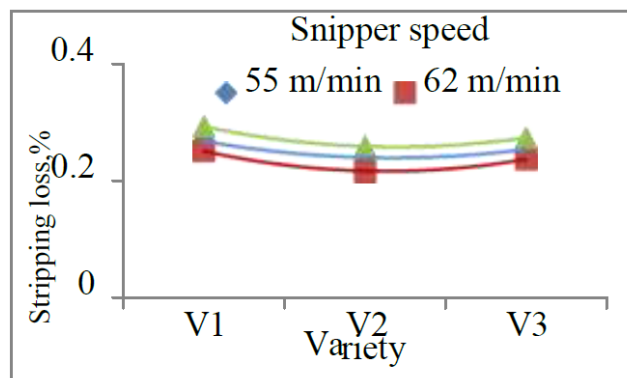
Note: F = Forward speed, S = Snipper speed, V = Variety



**Fig. 3. Effect of forward speed and snipper speed on stripping loss by maize cob harvester**



**Fig. 4. Effect of forward speed and variety on stripping loss by maize cob harvester**



**Fig. 5. Effect of snipper speed and variety on stripping loss by maize cob harvester**

forward speed the effect of stem length after harvesting was observed to be higher. It may be due to higher forward speed make the higher length of stem after harvesting at higher snipper speed. Fig. 6 depicts the effect of forward speed and snipper speed on length of stem after harvesting. It was found that there is significant

effect of both these parameters on length of stem after harvesting. It was observed highest at 2.1 km/h forward speed and snipper speed at 68 m/min. It may be due to higher forward speed make the higher length of stem after harvesting at higher snipper speed. Length of stem after harvesting was significantly effect of forward

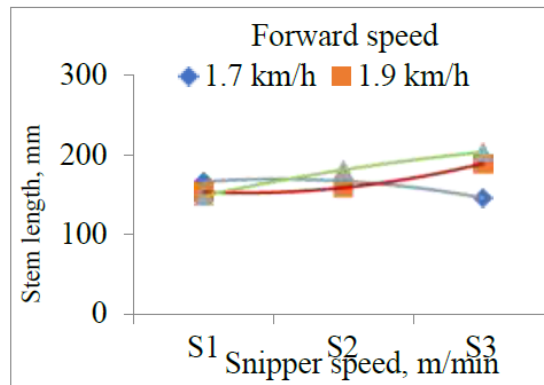
speed and variety (Fig. 4) It was observed highest at 1.7 km/h forward speed and at a variety of D-9081. It may be due to lower forward speed make the higher length of stem after harvesting at variety D-9081 from it. Fig. 8 depicts the effect of snipper speed and variety on length of stem after harvesting. It was found that

there is significant effect of both these parameters on length of stem after harvesting. It was observed that highest at snipper speed 68m/min at variety D-9081. It may be due to different size of maize crop variety and it has effects on the length of stem after harvesting.

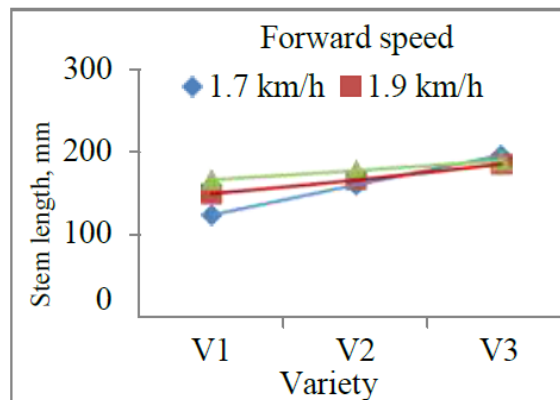
**Table 3. Effect of forward speed, snipper speed and variety, on effect of length of stem before and after harvesting**

| Forward speed, (km/h)                  | Length of stem after harvesting,(mm) |       |       |              |       |       |              |       |       |
|--|--------------------------------------|-------|-------|--------------|-------|-------|--------------|-------|-------|
|  | F1 (1.7 km/h)                        |       |       | F2(1.9 km/h) |       |       | F3(2.1 km/h) |       |       |
| Snipper speed, (m/min)                 | S(55)                                | S(62) | S(68) | S(55)        | S(62) | S(68) | S(55)        | S(62) | S(68) |
| Variety                                |                                      |       |       |              |       |       |              |       |       |
| V(Dhania-9965)                         | 123.3                                | 135.3 | 113.3 | 126.3        | 141.3 | 182   | 145.6        | 174   | 180   |
| V(Sartaj-765)                          | 164.3                                | 174.3 | 142.3 | 142          | 163   | 193.6 | 134.3        | 184.3 | 214   |
| V(D-9081)                              | 212.6                                | 192   | 182.6 | 191.3        | 172.6 | 192.3 | 166.6        | 185.6 | 217   |
| Factors                                |                                      |       |       |              |       |       | C.D          | SE(d) | SE(m) |
| Forward speedx Snipper speed x Variety |                                      |       |       |              |       |       | 2.873        | 1.428 | 1.01  |

Note: F = Forward speed, S = Snipper speed, V = Variety

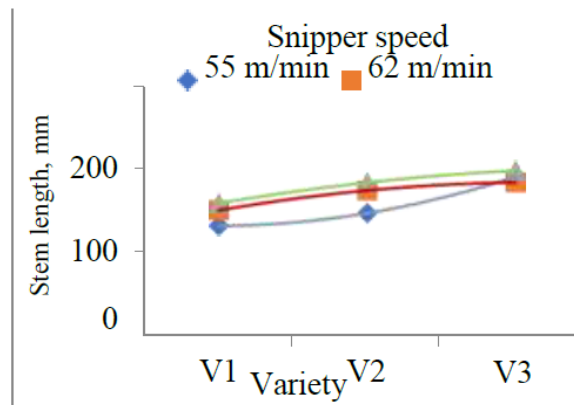


**Fig. 6. Effect of forward speed and snipper speed on length of stem after harvesting by maize cob harvester**



**Fig. 7. Effect of forward speed and variety on length of stem after harvesting by maize cob harvester**





**Fig. 8. Effect of snipper speed and variety on length of stem after harvesting by maize cob harvester**

### 3.3 Effect of Forward Speed, Snipper Speed and Different Variety, on actual Field Capacity by Maize Cob Harvester

The effect of forward speed and snipper speed at different maize crop variety, on actual field capacity was given in Table 4. It was observed that there is significant effect of all three on actual field capacity ( $\alpha=0.05$ ). It was also observed that actual field capacity was obtained as significantly highest (1.072 ha/h) at 1.7 km/h forward speed, 62 m/min snipper speed and variety D-9081. In higher forward speed the actual field capacity was observed to be higher. It may be due to higher forward speed make the higher actual field capacity at higher snipper speed. Fig. 9 depicts the effect of forward speed and snipper speed on actual field capacity. It was found that there is significant effect of both these parameters on actual field capacity. It was observed that highest at 2.1 km/h forward speed and snipper speed at 68 m/min. It may be due to higher forward speed make the higher actual field capacity at higher snipper speed.

Actual field capacity was significant effect of forward speed and variety (Fig. 10). It was observed highest at 1.9 km/h forward speed and at a variety of D-9081. It may be due to 1.9 km/h forward speed make the higher actual field capacity at variety D-9081 from it. Fig. 11 depicts the effect of snipper speed and variety on actual field capacity. It was found that there is significant effect of both these parameters on actual field capacity. It was observed highest at 62 m/min snipper speed and at a variety of D-9081. It may be due to 62 m/min snipper speed make the higher actual field capacity at variety D-9081 from it.

### 3.4 Effect of Forward Speed, Snipper Speed and Different Variety, on Field Efficiency by Maize Cob Harvester

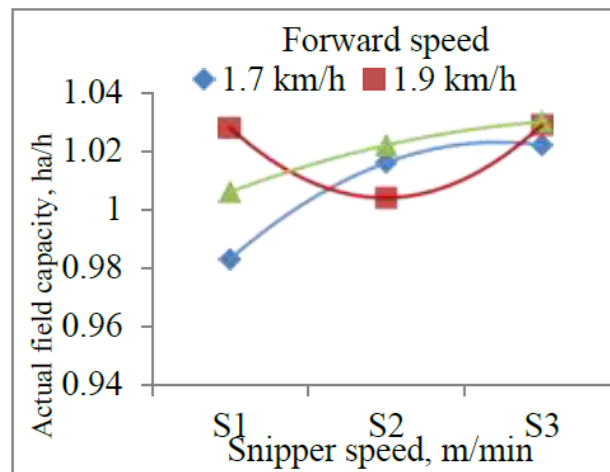
The effect of forward speed and snipper speed at different maize crop variety, on field efficiency was given in Table 5. It was observed that there is significant effect of all three on field efficiency ( $\alpha=0.05$ ). It may be due to variety of different size of maize cob, forward speed and snipper speed and it has effect on the field efficiency. It was also observed that field efficiency was obtained as significantly highest (95.613%) at 1.9 km/h forward speed, 68 m/min snipper speed and variety D-9081. In lower forward speed the field efficiency was observed to be higher. It may be due to variety of different size of maize crop have taken higher snipper speed as compared to less forward speed. Fig. 12 depicts the effect of forward speed and snipper speed on field efficiency. It was found that there is no significant effect of both these parameters on field efficiency. It may be due to variety of different size of maize crop have taken higher snipper speed as compared to less forward speed. It was observed highest at 1.9 km/h forward speed and snipper speed at 68 m/min. It may be due to 1.9 km/h forward speed make the higher length of cut at higher snipper speed. field efficiency was no significant effect of forward speed and variety (Fig. 13). It was observed highest at 1.9 km/h forward speed and at a variety of D-9081. It may be due no effect of forward speed to variety of different size of maize crop. It may be due to 1.9 km/h forward speed make the higher field efficiency at variety D-9081 from it. Fig. 14 depicts the effect of snipper speed and variety on field efficiency. It was found that there is no significant effect of both these parameters on field efficiency. It was observed highest at 68

m/min sniper speed and at a variety of D-9081. It may be no effect of sniper speed at size of different crop variety. It may be due to higher sniper speed make the higher field efficiency at variety D-9081.

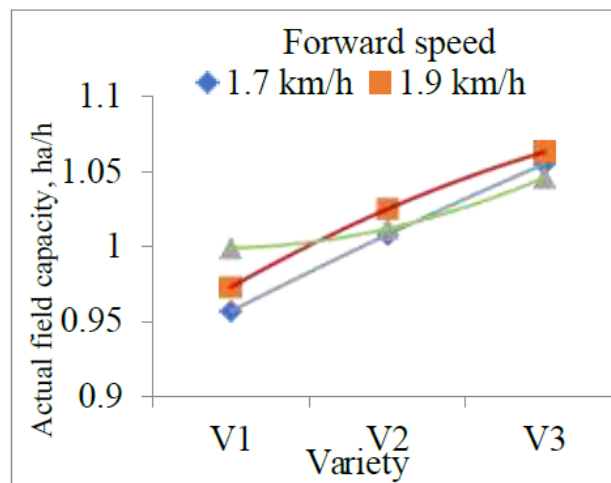
**Table 4. Effect of forward speed, sniper speed and variety, on actual field capacity**

| Forward speed, (km/h)                 | Actual field capacity,(ha/h) |       |        |             |       |       |             |       |       |
|---------------------------------------|------------------------------|-------|--------|-------------|-------|-------|-------------|-------|-------|
|                                       | F (1.7 km/h)                 |       |        | F(1.9 km/h) |       |       | F(2.1 km/h) |       |       |
| Sniper speed,(m/min)                  | S(55)                        | S(62) | S(68)  | S(55)       | S(62) | S(68) | S(55)       | S(62) | S(68) |
| Variety                               |                              |       |        |             |       |       |             |       |       |
| V(Dhania-9965)                        | 0.080                        | 0.081 | 0.0855 | 0.971       | 0.962 | 0.985 | 0.991       | 0.988 | 1.019 |
| V(Sartaj-765)                         | 0.971                        | 1.024 | 1.03   | 1.044       | 0.994 | 1.037 | 0.995       | 1.013 | 1.03  |
| V(D-9081)                             | 1.025                        | 1.072 | 1.069  | 1.068       | 1.057 | 1.064 | 1.033       | 1.064 | 1.042 |
| Factors                               |                              |       |        |             |       |       | C.D         | SE(d) | SE(m) |
| Forward speedx Sniper speed x Variety |                              |       |        |             |       |       | 0.026       | 0.013 | 0.009 |

Note: F = Forward speed, S = Sniper speed, V = Variety



**Fig. 9. Effect of forward speed and sniper speed on actual field capacity by maize cob harvester**



**Fig. 10. Effect of forward speed and variety on actual field capacity by maize cob harvester**



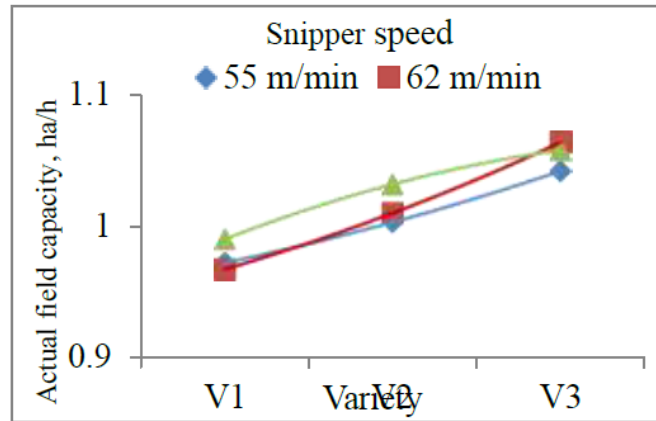


Fig. 11. Effect of snipper speed and variety on actual field capacity by maize cob harvester

Table 5. Effect of forward speed, snipper speed and variety, on actual field efficiency

| Forward speed, (km/h)                   | Field efficiency, (%) |        |        |             |        |        |             |        |        |
|---|-----------------------|--------|--------|-------------|--------|--------|-------------|--------|--------|
|   | F(1.7 km/h)           |        |        | F(1.9 km/h) |        |        | F(2.1 km/h) |        |        |
| Snipper speed, (m/min)                  | S(55)                 | S(62)  | S(68)  | S(55)       | S(62)  | S(68)  | S(55)       | S(62)  | S(68)  |
| Variety                                 |                       |        |        |             |        |        |             |        |        |
| V(Dhania-9965)                          | 81.32                 | 82.71  | 83.737 | 91.427      | 92.61  | 93.317 | 73.657      | 74.437 | 75.727 |
| V(Sartaj-765)                           | 82.457                | 83.557 | 84.523 | 92.567      | 93.777 | 94.487 | 74.38       | 75.74  | 76.67  |
| V(D-9081)                               | 83.667                | 84.69  | 85.383 | 93.597      | 94.437 | 95.613 | 75.783      | 76.77  | 77.537 |
| Factors                                 |                       |        |        |             |        |        | C.D         | SE(d)  | SE(m)  |
| Forward speed × Snipper speed × Variety |                       |        |        |             |        |        | 0.272       | 0.135  | 0.096  |

Note: F = Forward speed, S = Snipper speed, V = Variety

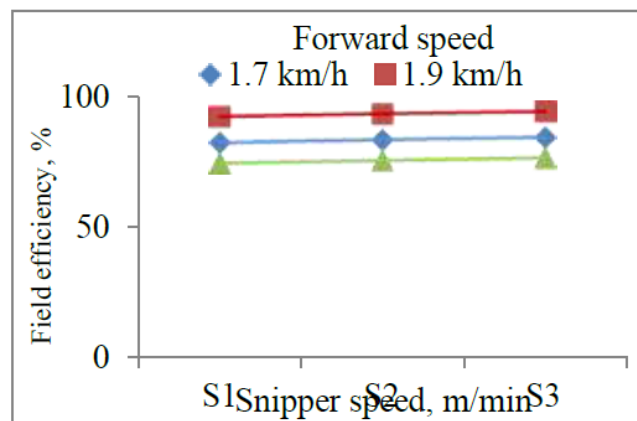


Fig. 12. Effect of forward speed and snipper speed on field efficiency by maize cob harvester

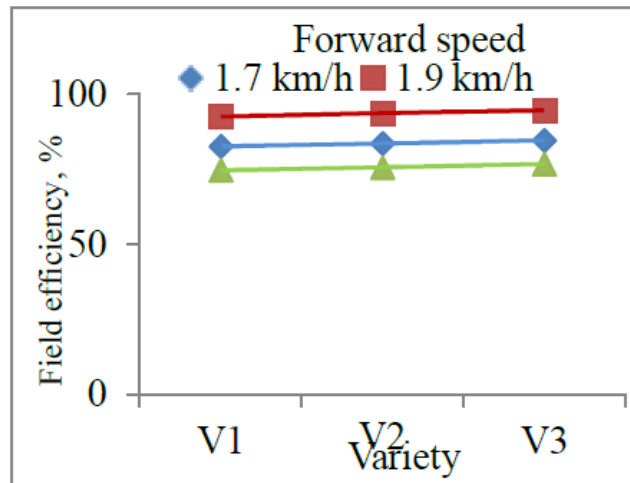


Fig. 13. Effect of forward speed and variety on field efficiency by maize cob harvester

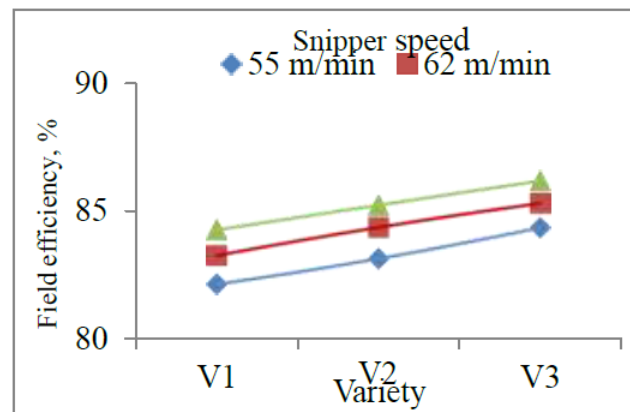


Fig. 14. Effect of snipper speed and variety on field efficiency by maize cob harvester

#### 4. CONCLUSION

The result on performance parameters revealed that the machine work satisfactorily at forward speed 1.9 km/h and snipper speed 62 m/min. The optimum stripping losses and length of stem after harvesting was found to be 0.197% and 825 mm. The highest field efficiency of 95.61 % was observed at 1.9 km/h forward speed, 68 m/min snipper speed and variety D-9081. The developed machine work efficiently 75%. Small size maize cob harvester is a machine to reduce the cost of harvesting and to reduce the drudgery. The cost of operation of machine was found as Rs.337.65 per hour, breakeven point was found as 149.64 h and payback period was 2.5 years (approx.) The total output of machine is 75 q/ha. Hence, it can be concluded that the maize cob harvester can cover one row at a time, it can harvest whole cob, cuts the stem in small

pieces and spread the mulch on the soil. The maize cob harvester works efficiently, It was also observed that the machines work satisfactorily at forward speed 1.9 km/h and snipper speed 62 m/min.

#### ACKNOWLEDGEMENTS

Authors are thankful to All India Coordinated Research Project on Farm Implement and Machinery (AICRP- FIM) to provide financial support for research. Authors are also thankful to department of farm machinery and power engineering, SV College of Agricultural Engineering and Technology and Research Station Indira Gandhi Krishi Vishwavidyalaya, Raipur India for providing essential facility for testing of the machine and helpful to performance evaluation of the maize cob harvester such as required field condition.

## COMPETING INTERESTS

Authors have declared that no competing interests exist.

## REFERENCES

1. Amer AH, Gomaa AH, Baiomy MH. Physical and mechanical characteristics for some agricultural residues. *Agricultural Engineering*. 2008;25:121-146.
2. Azadbakht M, Rezaei AA, Zahedi AT. Energy requirement for cutting corn stalks. *International Journal of Biological, Biomolecular, Agricultural, Food and Biotechnological Engineering*. 2014;8:479-482.
3. Bainer R, Kepner RA, Barger EL. *Principles of Farm Machinery*. First Edition, AVI Publishing Company, INC. Westport, Connecticut. 1956;81(2):155-158.
4. Wang KR, Xie RZ, Ming B, Hou P, Xue J, Li SK. Review of combine harvester losses for maize and influencing factors. *International Journal of Agriculture and Biological Engineering*. 2021;14:1-10.
5. Yang R, Chen D, Zha X, Pan Z, Shang S. Optimization design and experiment of ear-picking and threshing devices of corn plot kernel harvester. *Agriculture*. 2021;11(904):1-22.
6. Zhang Z, Chi RJ, Du YF, Pan X, Dong NX, Xie B. Experiments and modelling of mechanism analysis of maize picking loss. *International Journal of Agriculture & Biological Engineering*. 2021;14:11-19.
7. Bo Li, Shusen Li. Research on the security of improved design of knapsack brush cutter. *International Journal of Simulation, Systems, Science and Technology*. 2006;17:361-365.
8. Dange AR, Thakare SK. Force and energy required for cutting pigeon pea stems. *International Journal of Agricultural Engineering*. 2011;2:272-274.
9. Gang W, Honglei J, Tang L, Zhuang J, Xinming J. Design of variable screw pitch rib snapping roller and residue cutter for corn harvesters. *International Journal of Agriculture and Biological Engineering*. 2016;9:27-34.
10. Kongre UV, Shahare L, Mutkule A, Komawar A. Fabrication of multi crop cutter. *International Journal of Advanced Research in Science, Engineering and Technology*. 2016;3:1878-1883.
11. Shravani M, Mehta AK. Prototype development of a single row self-propelled maize cob picker cum stalk cutting machine. *Eco. Env. and Cons.* 2022;28(4):1738-1742.
12. Singh A, Bhullar KS. Harvesting and threshing of maize with a combined harvester. *International Journal of Agricultural Engineering*. 2016;9:249-251.
13. Thakur SS, Chandel R, Singh M. Technical, field and energy comparison of cutter bar maize header with snap roll maize header. *Journal of Agricultural Science*. 2021;3(4):2021.

© 2023 Garudik et al.; This is an Open Access article distributed under the terms of the Creative Commons Attribution License (<http://creativecommons.org/licenses/by/4.0>), which permits unrestricted use, distribution, and reproduction in any medium, provided the original work is properly cited.

Peer-review history:

The peer review history for this paper can be accessed here:  
<https://www.sdiarticle5.com/review-history/107546>